

REINFORCED CONCRETE PIPE



'A' INSIDE	'B' LAYING	'C' WALL	'D' BARREL	'E' REIN	'F' JOINT	WALL	D-LOAD
---------------	---------------	-------------	---------------	-------------	--------------	------	--------





Jensen Precast engineers, designs, and manufactures reinforced concrete pipe to meet the increasing demands of today's builders. Our precast concrete products stand the test of time.



REINFORCED CONCRETE PIPE

Paramount to the success of our communities are the type of structures we place underground. For engineers, contractors, and other deciding bodies, the need for high quality products is a big pull, yet so is the desire to keep costs low.

When it comes to underground pipe for sanitary sewers, storm drains, transportation infrastructure, and other applications, there is no substitute for reinforced concrete pipe. It solves for both expense and quality. It is durable and strong. It lasts over 100 years by relying on its own strength, not backfill. Most important, it offers corrosion protection and watertight features.

Here are a few things to consider when your project calls for pipe.

- What kind of pipe works best for your budget? Can you justify upfront costs versus longterm outcomes? Research your options and conduct a thorough cost benefit analysis before committing.
- How simple do you want your pipe installation? How much time do you have to complete the job? Expedite your project with easy to assemble pipe joints precast and ready to install.
- Do you need to guarantee product longevity? How much maintenance will the pipe you select need? Go with a product proven to last from 70 to 100 years with less time, care, and effort on soil prep.

Jensen Precast manufactures reinforced concrete pipe with state of the art pipe machinery, assuring world class quality, consistency, high output, and a range of size options. We are committed to the success of your project from first call to job completion.





DESIGN

- Select structurally superior, hydraulically efficient, and environmentally sensitive pipe for your projects.
- Specify products that meet and exceed ASTM C-76 standards and undergo regular D-load testing in accordance with ASTM C-497.



BID

- Stay within your project budget without sacrificing product quality, onsite expertise, and accommodating delivery choices.
- Gain an accurate and complete takeoff from our experienced estimators to win your bid.



BUILD

- Assure complete, timely, and hassle free product attainment due to our large inventory.
- Leverage our installation friendly features to expedite your project with options such as Easy-Lift.
- Take advantage of our abundant and easily accessible industry resources for installation, follow up, and usage.



APPLICATIONS

- Sanitary sewers
- Storm sewers
- Storm drains
- Culvert connections
- Irrigation systems
- Outfalls
- Tunneling and jacking
- Stormwater detention and retention
- Wet weather flow management
- Utility tunnels
- Transportation infrastructure



SOLUTIONS

STRENGTH & DURABILITY

- Concrete pipe is the strongest pipe available and can be designed and tested to withstand any load.
- The Army Corp of Engineers recommends a design life of 70 to 100 years, and there are countless examples of reinforced concrete pipe installations that surpass those numbers.

STRUCTURE & CONDUIT

- Concrete pipe is a ridged pipe that inherently provides structure and conduit making it over 85% dependent on the pipe strength and only 15% dependent on the soil envelope.
- The structural strength of the pipe allows higher fill height and trench depths.
- Flexible pipe is at least 95% dependent on soil support and the installation of the contractor. Backfill must be properly engineered and installed to provide structure. Reinforced concrete pipe eliminates those challenges.
- Concrete pipe maintains its shape and does not deflect during installation.

JOINTS

- Concrete pipe joints are designed for soil tightness and water tightness with the ability to accommodate later to accommodate lateral or longitudinal movement by using several joint options including mortar, flexible joint sealants, rubber gaskets, and external sealing bands.
- Jensen Precast offers various joint types including mortar joint, gasket, and o-ring gasket.



CIRCULAR REINFORCED CONCRETE PIPE

Jensen Precast durable, dependable, and economical pipe comes in Class III, IV, and IV to meet the project specifications. Make turns and connections with tees and wyes, and terminate pipe with plugs, flared ends, and headwalls. Available with tongue and groove, single offset gasket, and o-ring gasket.

Class	III	IV	V
Loading (lb/ft/ft)	1350	2000	3000

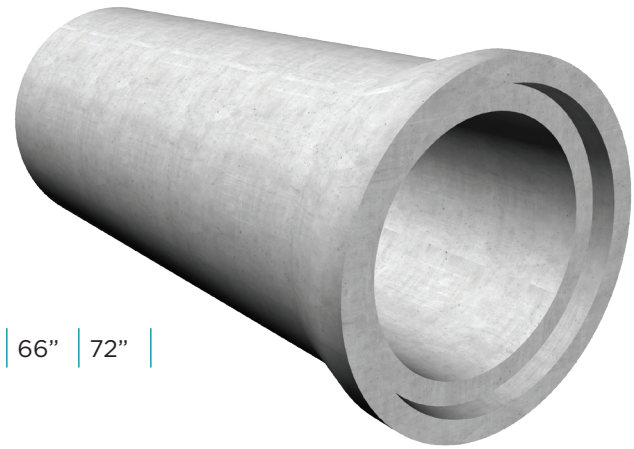

Size | 12" | 15" | 18" | 24" | 30" | 36" | 42" | 48" | 54" | 60" | 66" | 72" |



ELLIPTICAL PIPE

For applications with depth of bury restrictions, elliptical pipe can provide higher flow capacity at shallower depths

Round Equivalent	18"	24"	30"	36"	42"	48"	54"	60"
Elliptical (rise x span)	14" x 19"	19" x 30"	24" x 38"	29" x 45"	34" x 53"	38" x 60"	43" x 68"	48" x 76"

HEADWALLS & WINGWALLS

Finish and secure the end of pipe for a sound, functional, and permanent installation. Our products are designed to meet standards for many major agencies including Arizona Department of Transportation, Caltrans, Nevada Department of Transportation, and Maricopa Association of Governments.

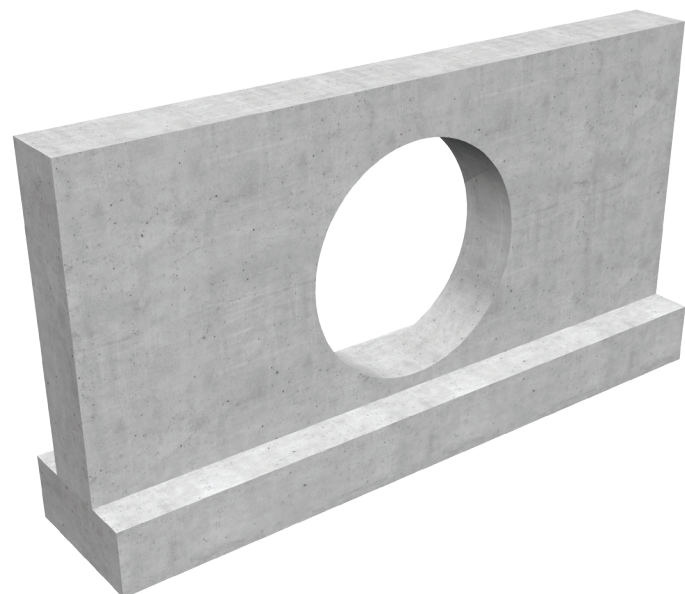

RELATED PRODUCTS

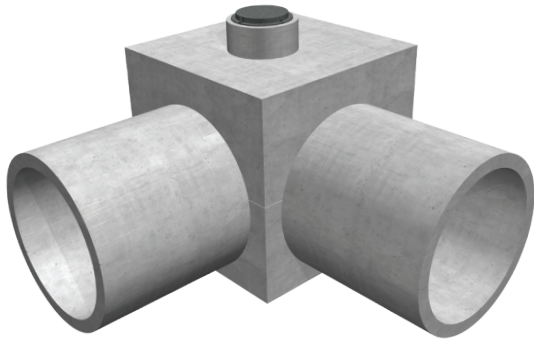

DROP INLETS



MANHOLES

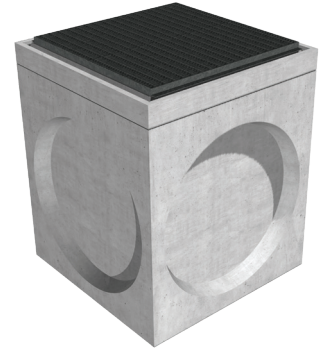

JUNCTION BOXES

EASY-LIFT FEATURE

Standard reinforced concrete pipe is typically installed using two machines plus four or more ground crew. Easy-Lift Reinforced Pipe, a patented product available only from Jensen Precast, enables a two person ground crew with one lifting machine and operator to easily install your pipe faster than ever before.

SOLVE FOR EFFICIENCY

- Eliminate forklift equipment, operator, and handling operations required to raise reinforced concrete pipe for crew members to manually place belly bands and eliminate the in-trench step of removing belly bands.
- No more ground crew members at risk painstakingly measuring belly band placement and carefully installing belly bands to balance the lifting point on every stick of pipe while the trench crew waits.
- Easy-Lift balanced pivot point means much less effort required in the trench to align each pipe stick against the force of front-and-back lifting points.

Jensen Precast Easy-Lift Reinforced Concrete Pipe is available for sizes ranging from 12" to 60".



Jensen Precast designs, engineers, and manufactures precast concrete products for the growing infrastructure needs of communities, businesses, and government agencies.



**IRRIGATION
WATER
CONTROL**



**CONCRETE
FENCE**



**STORMWATER
SYSTEMS**



**BOX
CULVERT**



**UTILITY
STRUCTURES
NATURAL GAS**



**DRAINAGE
INLETS &
CATCH BASINS**



**SEWER &
STORM DRAIN
MANHOLES**



**EARTH
RETENTION
SYSTEMS**



**UTILITY
STRUCTURES
TELECOM**



**UNDERGROUND
ENCLOSURES**



**UTILITY
STRUCTURES
ELECTRIC**

LOCATIONS & CONTACT

CORPORATE OFFICE

Reno, Nevada
(775) 352-2700

ARIZONA

Phoenix (602) 268-0228
Tucson (520) 748-1607

CALIFORNIA

Fontana (909) 350-4111
Kingsburg (559) 248-0270
Lakeside (619) 219-8430
Lockeford (209) 727-5573
Martinez (925) 222-3471
Ontario (909) 983-9789
Orland (530) 865-4277
Sacramento (916) 991-8800
Santa Rosa (916) 991-8800

HAWAII

Kapolei (808) 528-1175

NEVADA

Las Vegas (702) 649-0045
Sparks (775) 359-6200

WASHINGTON

Camas (360) 834-3459
Puyallup (253) 929-1818
Shelton (253) 884-4008

Jensen Precast is ready to assist you with job quotes, designs, and products. Contact your nearest branch location or reach us at (775) 352-2700 or info@jensenprecast.com



For more information, go to jensenprecast.com